

Diaphragm Pumps for Air, Gases and Vapours

INNOVATIVE
TECHNOLOGY
WORLDWIDE

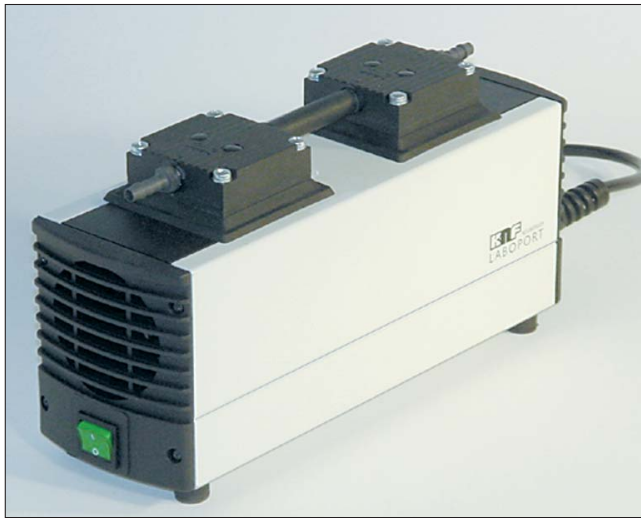

LABOPORT® Mini Diaphragm Vacuum Pumps

Technical features:

- 100% oil-free transfer
- Pure transfer, evacuation and compression
- For slightly aggressive or corrosive gases and vapours
- Maintenance-free
- Environmentally friendly
- Gastight, leakage rate approx. 6×10^{-3} mbar x l/s, not tested in serial production.

Series LABOPORT® N 816.3 K_.18 Pumps

Series N 816.3 diaphragm pumps are double-head, dry-running devices used in a wide range of laboratory applications. They transfer and pump down without contamination.

The heart of these very compact pumps is a KNF structured diaphragm. This patented diaphragm was stress-optimized using the Finite Elements method. As a result, we were able to make the pumps smaller while increasing the service life of the diaphragm.

The pumps are available in various versions differing in the materials which contact the media.

Technical data:	N 816.3 KN.18	N 816.3 KT.18
Delivery (l/min) ¹⁾	16	16
Ultimate vacuum (mbar abs.)	15	20
Operating pressure (bar g)	0.5	0.5
Connectors for tube (mm)	ID 6	ID 6
Permissible gas and ambient temperature	+5...+40 °C	+5...+40 °C
Voltage/Frequencies	230V/50Hz	230V/50Hz
Motor protection	IP 20	IP 20
Power P ₁	100 W	100 W
Operating current	0.6 A	0.6 A
Weight	3.95 kg	3.95 kg
Dimensions LxHxW (mm)	361/141/90	361/141/90
With thermal switch and power fuse		

Material in contact with the pumped media

Type/OrderNo.	Pump head	Diaphragm	Valves
N 816.3 KN.18	PPS	EPDM	EPDM
N 816.3 KT.18	PPS	PTFE-coated	FFPM

Motors with other voltages and frequencies on request.

¹⁾ at atm. pressure

Dimensions and performance characteristics

Pump down time for 10 l receiver

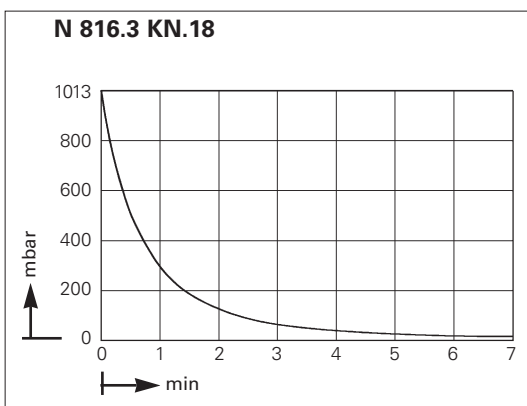

Performance characteristics

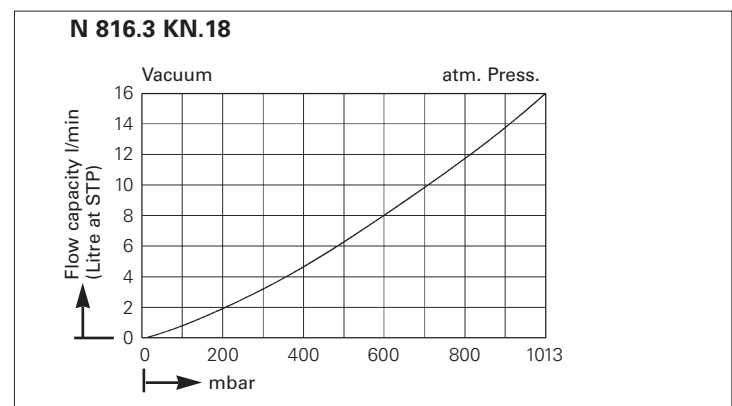

Diaphragm Pumps for Air, Gases and Vapours

INNOVATIVE
TECHNOLOGY
WORLDWIDE

KNF
NEUBERGER

Pump down time for 10 l receiver

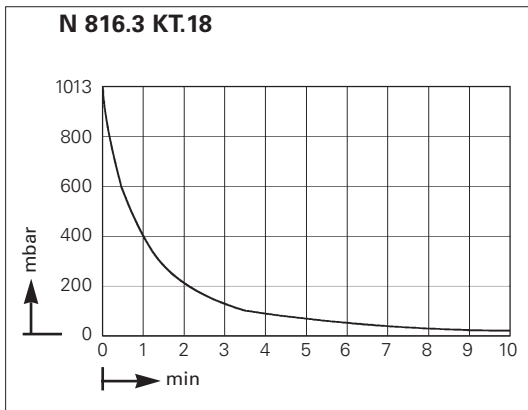

Performance characteristics

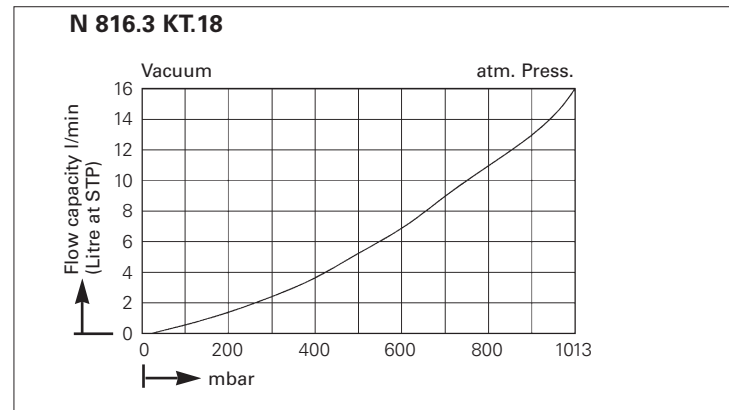

Dimensions (mm)

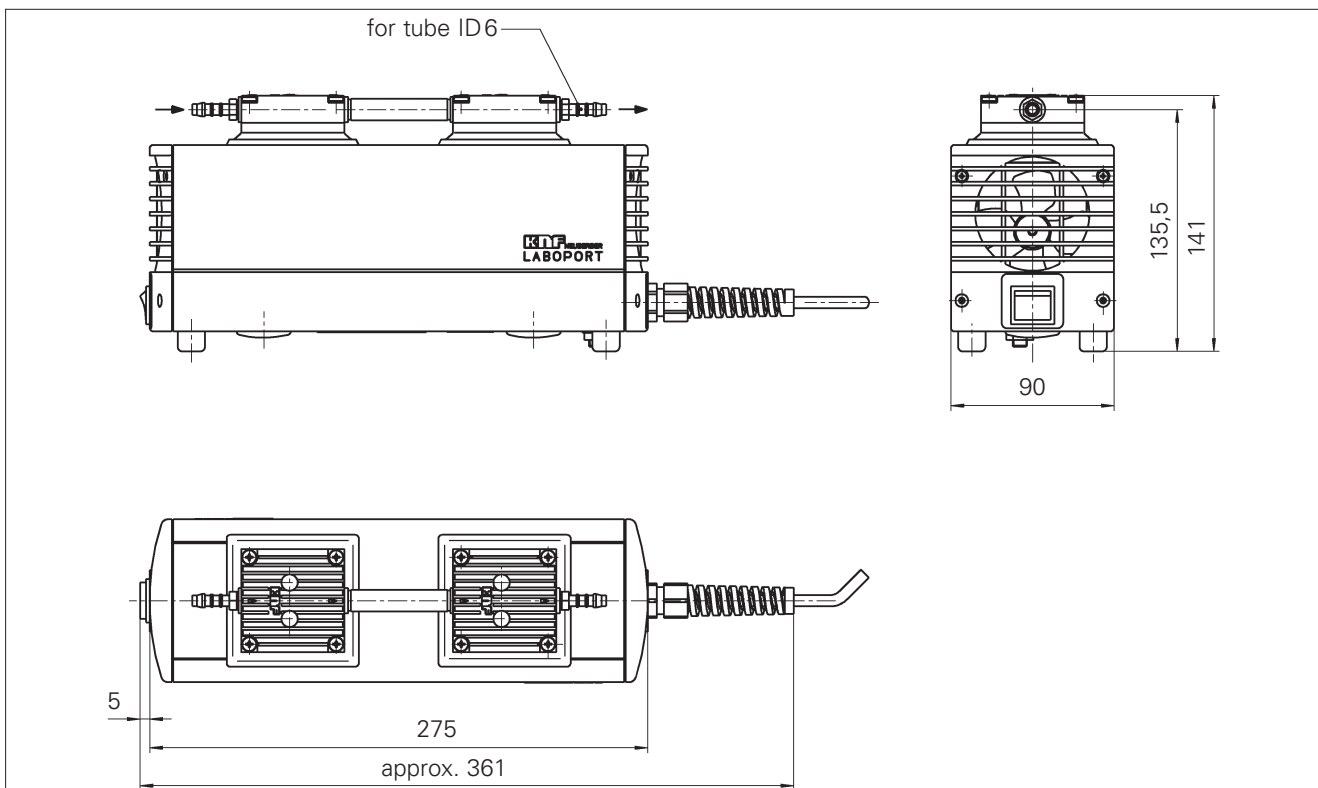

Accessories

Description	Details	Order No.
Silencer	G 1/8	000345
Hose connector	G 1/8, PVDF, AD 6 mm	014052
Fine control valve with vacuum gauge	suction side	on request