

# DIAPHRAGM LIQUID PUMPS

## NF 100 / 1.100

DATA SHEET E 515

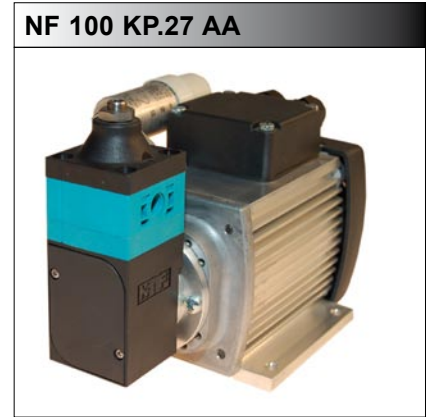

### Concept

KNF diaphragm liquid pumps are based on the principle of the oscillating displacement pump which is remarkably simple in design. The circular power from the motor is converted into vertical movement by an eccentric. This motion is then transferred to a diaphragm by means of a connecting rod which in conjunction with an inlet and outlet valve creates a pumping action.

NF 100/1.100 type liquid pumps can be mounted in any position and can deliver up to 1.3 l/min depending on the model and will operate against pressures of up to 60 mWg.

The KNF modular system contains a wide standard range of materials, motors, voltages and frequencies to enable the selection of an optimal solution for your application.

### Features

#### Self-priming and excellent for pressure

Sophisticated diaphragm technology and precise valve structures enable performances, depending on model, of up to 4 mWg suction and 60 mWg pressure.

#### Extreme chemical resistance

The use of chemically resistant materials such as PTFE, PVDF, FFPM or other material combinations for the parts which come in contact with the liquid allows almost all neutral or corrosive liquids to be pumped.

#### Dry running, durable and maintenance free

The carefully considered design of these pumps allows them to be run dry and ensures safe operation and a long life even under the most severe conditions.

### Areas of use

The versatility of KNF pumps allows a wide field of applications to be covered. Over many years our pumps have proved themselves in the following areas:

#### Analysers

- Medical / pharmaceutical
- Environmental / water treatment
- Food / toxicology

#### Laboratory

- Filtration
- Chromatography

#### Cleaning industry

- Cuvette cleaning
- Sterilisers
- Industrial washing machines

#### Printing

- Ink jet printing
- Photographic / film development

Other applications for diaphragm liquid pumps include: fuel cells, hydrogen generators, CD coating, dental technology, textiles and many more.

## Performance Data

Type	Flow rate (l/min)	Suction head (mWg)	Pressure head (mWg)
NF 100	1.2	3	10
NF 1.100	1.3	3	60

# Basic models



## General note

This Data Sheet provides an overview of the options with our NF 100/1.100 pumps. Certain standard options will be explained in more detail where necessary.

## Flow curves

The flow curves illustrate how the flow rate alters in relation to the pressures before and after the pump. In the case of a combination of both we would be very happy to advise what the expected flow rate would be.

The values given in the curves are dependant upon the liquid, choice of head materials and the type of hoses being used. Therefore a certain deviation is to be expected.

**Note: The flow rate is measured with water at 20°C.**

## Basic models

NF 100	Liquid diaphragm pump for pressures of up to 10 mWg (1 barg)
NF 1.100	Liquid diaphragm pump for pressures of up to 60 mWg (6 barg)

## 1 Materials of head components

KNF FLODOS offers a wide range of different materials for those parts which come in contact with the liquid thus allowing the possibility of pumping most liquids.

## 2 Head types

### - Standard

The pump head of the NF 100/1.100 is made up of eight main parts. The diaphragm, intermediate plate, connection plate, O-Ring, resonating diaphragm and the valves are the only parts which come in contact with the liquid. The materials which are available as standard can be seen in the table.

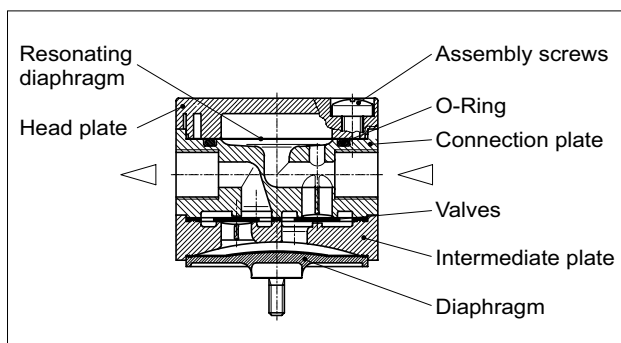

## .27 Integrated overpressure relief valve

The integrated overpressure relief valve is available for all NF 100/1.100 pumps.

### How it works

If the pump runs against a closed system the pressure will increase rapidly thus exceeding the allowed limits. In order to prevent this from happening a relief valve has been integrated into the head. Should the pressure exceed the adjusted value (min. 0.5 barg), the valve will open allowing the liquid to pass through the built-in bypass from the outlet to the inlet side.

**Note: The valve is adjusted in the factory to a standard value of 1.5 barg (NF 100) and 6.5 barg (NF 1.100).**

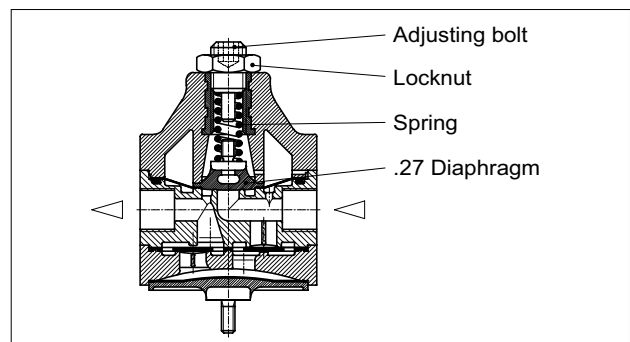

### Areas of use

The valve can be used to prevent damage from occurring to the pump itself, hoses, valves and the system as a whole due to excessive pressures which can build up because of blockages or faulty valves.

## 3 Motors

- E Shaded pole motor (AC)
- AA Capacitor motor (AC)
- DC Direct current motor
- DCB Brushless direct current motor  
This type of motor has no brushes which can wear down thus giving it a lifetime comparable with an AC motor.  
Option: control possibility via PWM or 0-5V DC signal

## 4 Voltages / Frequencies

Choose from the different electrical connection possibilities. Special variations are available.

# NF 100-E / AA

# NF 100-DC / DCB



## Performance

Basic model	Flow rate at atmos. pressure (l/min)	Max. suction head (mWg)	Max. pressure head (mWg)
NF 100-E	1.2	3	10
NF 100-AA	1.2	3	10

Motor selection	E	AA
Voltage (V)	230V / 50Hz	230V / 50Hz
Power rating (W)	43	86
I max. load (A)	0.37	0.36
I max. (A)	0.43	0.50
EMC guideline	EN 55014	EN 55014
Motor protection factor	IP 00	IP 54
Weight	1100 g	2430 g

## Performance

Basic model	Flow rate at atmos. pressure (l/min)	Max. suction head (mWg)	Max. pressure head (mWg)
NF 100-DC	1.2	3	10
NF 100-DCB	1.2	3	10

Motor selection	DC	DCB
Voltage (V)	6 / 12 / 24	12 / 24
Power rating (W)	26 / 26 / 24	11 / 11
I max. load (A)	1.07 / 0.9 / 0.3	0.67 / 0.37
I max. (A)	4.4 / 2.2 / 1.0	0.93 / 0.46
EMC guideline	EN 55014	EN 55014-1 <sup>1)</sup> EN 61000-2-6
Motor protection factor	IP 50	IP 30
Weight	600 g	480 g

<sup>1)</sup> In order to comply with the above standards attention must be paid to the specifications in the operating instructions.

### NF 100-E

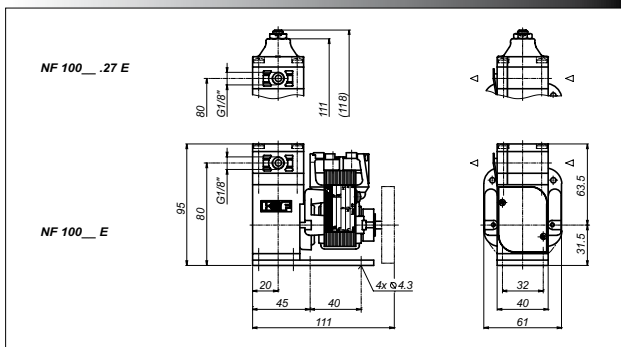

### NF 100-DC

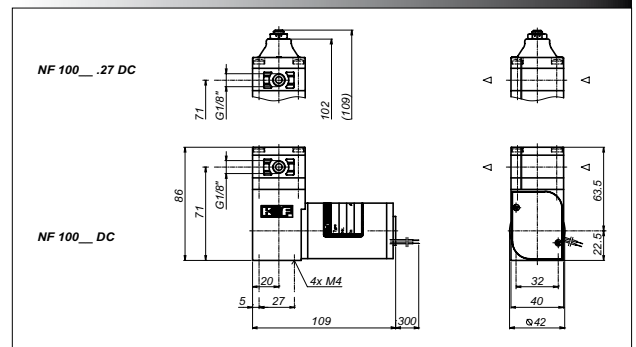

### NF 100-AA

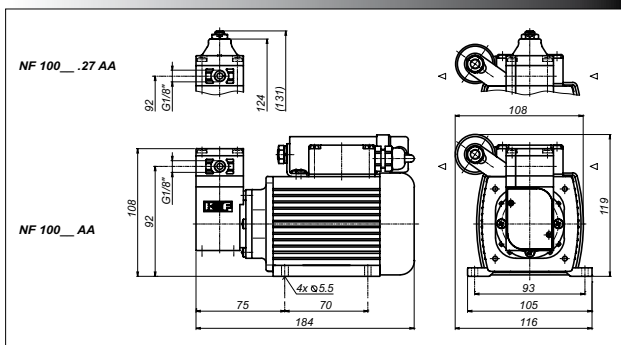

### NF 100-DCB

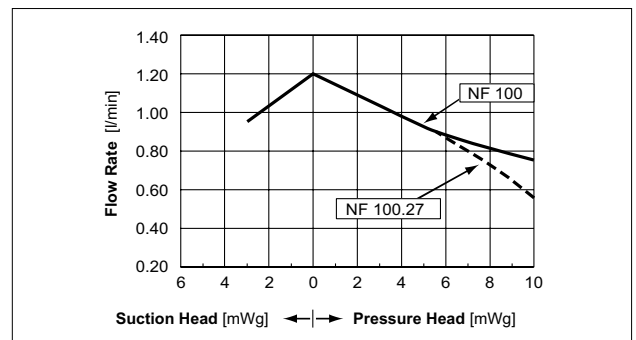
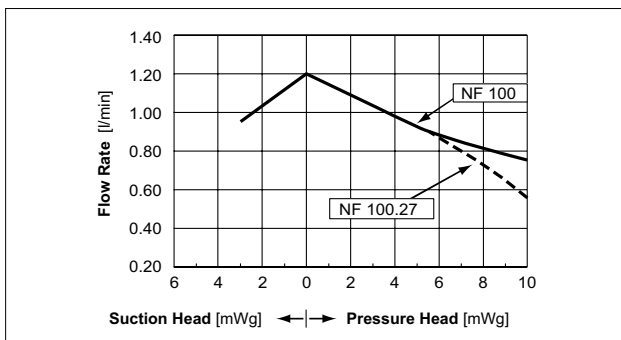
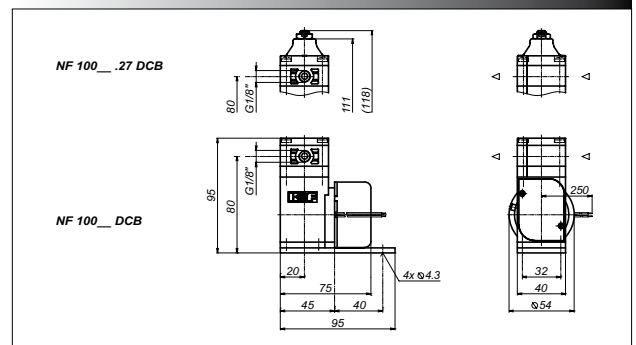

# NF 1.100-E / AA

# NF 1.100-DC / DCB



## Performance

Basic model	Flow rate at atmos. pressure (l/min)	Max. suction head (mWg)	Max. pressure head (mWg)
NF 1.100-E	1.3	3	60
NF 1.100-AA	1.3	3	60

Motor selection	E	AA
Voltage (V)	230V / 50Hz	230V / 50Hz
Power rating (W)	66	86
I max. load (A)	0.42	0.36
I max. (A)	0.50	0.50
EMC guideline	EN 55014	EN 55014
Motor protection factor	IP 00	IP 54
Weight	1600 g	2450 g

## Performance

Basic model	Flow rate at atmos. pressure (l/min)	Max. suction head (mWg)	Max. pressure head (mWg)
NF 1.100-DC	1.3	3	60
NF 1.100-DCB	1.3	3	60

Motor selection	DC	DCB
Voltage (V)	6 / 12 / 24	12 / 24
Power rating (W)	39 / 33 / 34	18 / 18
I max. load (A)	2.7 / 1.3 / 0.5	1.29 / 0.75
I max. (A)	6.5 / 2.8 / 1.0	1.50 / 0.75
EMC guideline	EN 55014	EN 55014-1 <sup>1)</sup> EN 61000-2-6
Motor protection factor	IP 50	IP 30
Weight	720 g	500 g

<sup>1)</sup> In order to comply with the above standards attention must be paid to the specifications in the operating instructions.

### NF 1.100-E

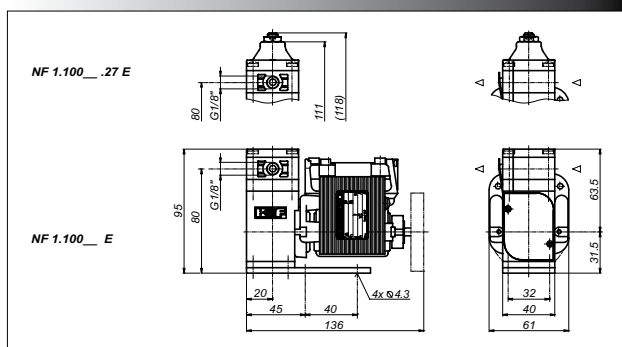

### NF 1.100-DC

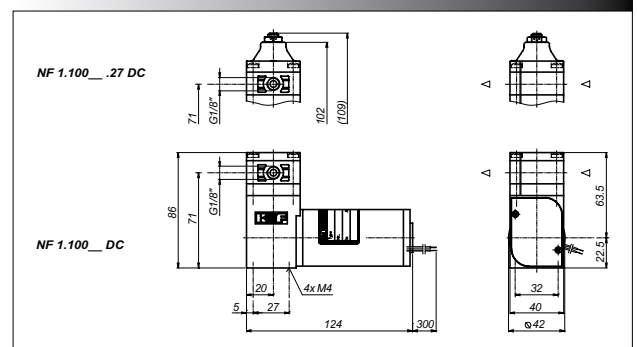

### NF 1.100-AA

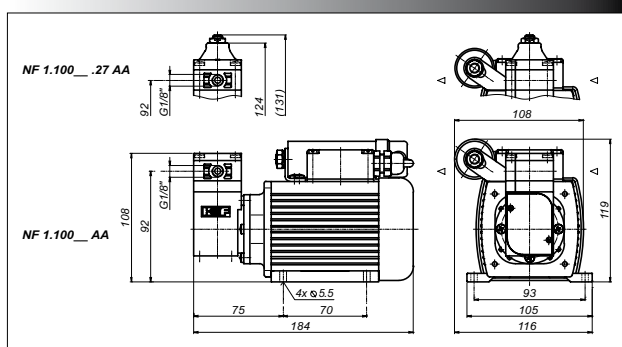

### NF 1.100-DCB

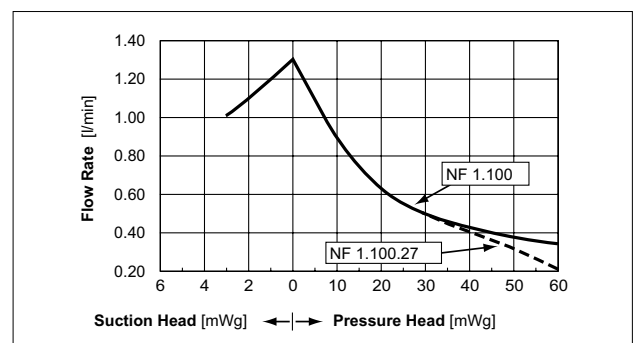
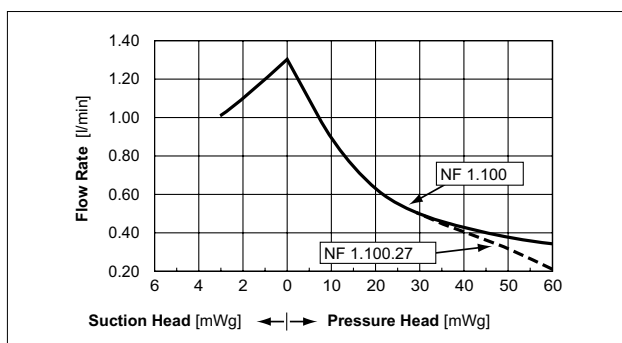
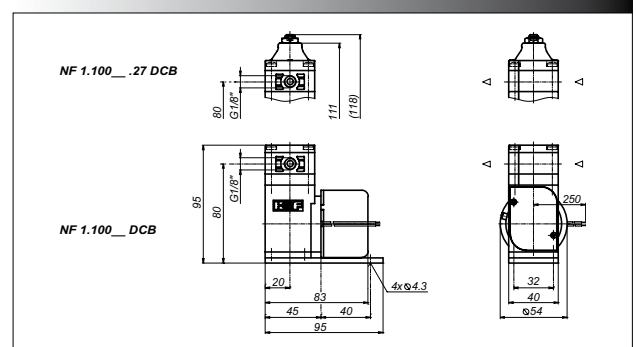

# The KNF Modular Concept of Selection



Our versatile self-selection program allows you to personally determine the optimum characteristics that you require from your pump. Select your diaphragm pump from the following characteristics:

Flow rate at atmos. pressure (l/min)	Max. suction head (mWg)	Max. pressure head (mWg)	Pump type				
			Basic model	Components			
				1	2	3	4
█ 1.2	3 █	█ 10	<b>NF 100</b>				
█ 1.3	3 █	█ 60	<b>NF 1.100</b>				

1	Materials of head components	
KP / KP .51*	Head	PP
	Valves	EPDM
	Diaphragm	PTFE
	Resonating diaphragm	PTFE
	O-Ring	EPDM
	.27 Diaphragm	EPDM
KT	Head	PP
	Valves	FFPM
	Diaphragm	PTFE
	Resonating diaphragm	PTFE
	O-Ring	PTFE
	.27 Diaphragm	FFPM
TT	Head	PVDF
	Valves	FFPM
	Diaphragm	PTFE
	Resonating diaphragm	PTFE
	O-Ring	PTFE
	.27 Diaphragm	FFPM
FT	Head	PTFE
	Valves	FFPM
	Diaphragm	PTFE
	Resonating diaphragm	PTFE
	O-Ring	PTFE
		PTFE

2	Head types
-	Standard model
.27	Integrated overpress. relief valve

3	Motors
E	Shaded pole motor (AC)
AA	Capacitor motor (AC)
DC	Direct current motor
DCB	Brushless direct current motor

4	Voltages / Frequencies
230V / 50Hz 115V / 60Hz 100V / 50-60Hz	for AC motors
6 / 12 / 24V	for DC motors
12 / 24V	for DCB motors

\* food conform according to the standard NSF/ANSI 169, for further information see options



### Diaphragm pressure control valve

The pressure control valve can be used for a more accurate control of flow against a fluctuating back pressure, metering into a vacuum and from a pressurised system. Used correct it can save pumps, plumbings and other fittings from damage. Example FDV 30 KPZ, for more information see data sheet FDV



### Pulsation damper

This very versatile pulsation damper reduces the vibration in hoses and pipes and it helps to remove pulsation which is preventing the system from functioning correctly. It also protects instrumentation connected after the pump. Suggestion FPD 06 KPZ-1, for more details see data sheet FPD

### Further accessories

- Hoses
- Hoses connections
- Shock mounts
- Suppression device for DCB motor (ID-No. 068713)



### NSF National Sanitary Foundation

NSF is market leader in the development and controlling of standards relevant for equipment used for handling foodstuffs. By using different toxicological tests our products will be certified according to the standard NSF/ANSI 169. This certification will confirm that all of the pumps with the code .51 are certified for the use with foods/consumables. In addition to this it also means that the pumps are constructed with wetted parts which come with a FDA\* declaration of conformity. A yearly audit from NSF will be carried out to ensure that these standards are being maintained. A list of the various products are available on request.

\* FDA = Food and Drug Administration

### Tandem version (twin headed pump)

The tandem liquid diaphragm pump allows two pump heads to be driven by one motor and is available with AC or DC motors.

### ATEX-explosion proof motors

For pumping liquids in explosive atmospheres we offer the NF 1.100 EX equipped with the KNF Ex-motor.

### Further options

- Connection threads NPT 1/8"
- Variable head materials
- Motors with special frequencies and voltages
- The incorporation of customers special requirements, for example special electrical connections (Molex, AMP etc.)

**We specialise in tailor made solutions. For all the possible options please feel free to contact us.**

KNF FLODOS AG, Wassermatte 2, 6210 Sursee, Switzerland - [www.knf-flodos.ch](http://www.knf-flodos.ch), [info@knf-flodos.ch](mailto:info@knf-flodos.ch)

