

# MICRO DIAPHRAGM LIQUID PUMPS NF 60 / 61

DATA SHEET E 514



## Concept

KNF micro diaphragm liquid pumps are based on the principle of the oscillating displacement pump which is remarkably simple in design. The circular power from the motor is converted into vertical movement by an eccentric. This motion is then transferred to a diaphragm by means of a connecting rod which in conjunction with an inlet and outlet valve creates a pumping action.

NF 60/61 type liquid pumps can be mounted in any position and can deliver up to 0.6 l/min depending on the model and will operate against pressures of up to 10 mWg.

The KNF modular system contains a wide standard range of materials, motors, voltages and frequencies to enable the selection of an optimal solution for your application.



## Features

### Small and powerful

Micro design and maximum performance resulting from built-in technology are the outstanding characteristics of this product.

### Self-priming and excellent for pressure

Sophisticated diaphragm technology and precise valve structures enable performances of up to 5 mWg suction and 10 mWg pressure.

### Extreme chemical resistance

The use of chemically resistant materials such as PTFE, PVDF, FFPM or other material combinations for the parts which come in contact with the liquid allows almost all neutral or corrosive liquids to be pumped.

### Dry running, durable and maintenance free

The carefully considered design of these pumps allows them to be run dry and ensures safe operation and a long life even under the most severe conditions.



## Areas of use

The versatility of KNF pumps allows a wide field of applications to be covered. Over many years our pumps have proved themselves in the following areas:

### Analysers

- Medical / pharmaceutical
- Environmental / water treatment
- Food / toxicology

### Laboratory

- Filtration
- Chromatography

### Cleaning industry

- Cuvette cleaning
- Sterilisers
- Industrial washing machines

### Printing

- Ink jet printing
- Photographic / film development

Other applications for diaphragm liquid pumps include: fuel cells, hydrogen generators, CD coating, dental technology, textiles and many more.

## Performance Data

Type	Flow rate (l/min)	Suction head (mWg)	Pressure head (mWg)
NF 60/61	0.6	3	10
NFB 60	2 x 0.6	3	10

# The KNF Modular Concept of Selection



## General note

This Data Sheet provides an overview of the options with our NF 60/61 pumps. Certain standard options will be explained in more detail where necessary.

## Flow curves

The flow curves illustrate how the flow rate alters in relation to the pressures before and after the pump. In the case of a combination of both we would be very happy to advise what the expected flow rate would be.

The values given in the curves are dependant upon the liquid, choice of head materials and the type of hoses being used. Therefore a certain deviation is to be expected.

**Note: The flow rate is measured with water at 20°C.**

## 1 Materials of head components

KNF FLODOS offers a wide range of different materials for those parts which come in contact with the liquid thus allowing the possibility of pumping most liquids.

## 2 Motors

E Shaded pole motor (AC)

DC Direct current motor

NF 61 Ironless direct current motor

This provides the following advantages compared to a conventional DC motor: higher durability, less power consumption and smaller size.

DCB Brushless direct current motor

This type of motor has no brushes which can wear down thus giving it a lifetime comparable with an AC motor.  
Option: control possibility via PWM or 0-5V DC signal

## 3 Voltages / Frequencies

Choose from the different electrical connection possibilities. Special variations are available.

## Modules

Our versatile self-selection program allows you to personally determine the optimum characteristics that you require from your pump. Select your diaphragm pump from the following characteristics:

Pump type			
Basic model	Components		
	1	2	3
NF 60/61			
NFB 60			

1	Materials of head components	
KP* / KP .51**	Head Valves O-Ring Diaphragm Resonating diaphragm	PP EPDM EPDM PTFE PTFE
KV	Head Valves O-Ring Diaphragm Resonating diaphragm	PP FPM (Viton) FPM (Viton) PTFE PTFE
KT*	Head Valves O-Ring Diaphragm Resonating diaphragm	PP FFPM PTFE PTFE PTFE
TV	Head Valves O-Ring Diaphragm Resonating diaphragm	PVDF FPM (Viton) FPM (Viton) PTFE PTFE
TT*	Head Valves O-Ring Diaphragm Resonating diaphragm	PVDF FFPM PTFE PTFE PTFE
FT	Head Valves O-Ring Diaphragm Resonating diaphragm	PTFE FFPM PTFE PTFE PTFE

2	Motors
E	Shaded pole motor (AC)
DC	Direct current motor
DCB*	Brushless direct current motor

3	Voltages / Frequencies
230V / 50Hz 115V / 60Hz 100V / 50-60Hz	for AC motors
6 / 12 / 24V	for DC motors
12 / 24V*	for DCB motors

\* NFB is only in this versions as standard available. Other versions on request.

\* food conformity according to the standard NSF/ANSI 169, details see options

# NF 60-E / DCB

# NF 60 / 61-DC



## Performance

Basic model	Flow rate at atmos. pressure (l/min)	Max. suction head (mWg)	Max. pressure head (mWg)
NF 60-E	0.6	3	10
NF 60-DCB	0.6	3	10

Motor selection	E	DCB
Voltage (V)	230V / 50Hz	12 / 24
Power rating (W)	26	11.2 / 11
I max. load (A)	0.21	0.64 / 0.34
I max. (A)	0.22	0.93 / 0.46
EMC guideline	EN 55014	EN 55014-1 <sup>1)</sup> EN 61000-2-6
Motor protection factor	IP 00	IP 30
Weight	580 g	280 g

<sup>1)</sup> In order to comply with the above standards attention must be paid to the specifications in the operating instructions.

## Performance

Basic model	Flow rate at atmos. pressure (l/min)	Max. suction head (mWg)	Max. pressure head (mWg)
NF 60-DC	0.6	3	10
NF 61-DC	0.6	3	10

Motor selection	DC (NF 60)	DC (NF 61)
Voltage (V)	6 / 12 / 24	6 / 12 / 24
Power rating (W)	11.3/11.9/12.2	7.2 / 7.8 / 7.8
I max. load (A)	1.25/0.69/0.36	0.92/0.58/0.3
I max. (A)	1.88/0.99/0.51	1.2/0.65/0.33
EMC guideline	EN 55014	EN 55022 EN 55011
Motor protection factor	IP 00	IP 33
Weight	190 g	230 g

### NF 60-E

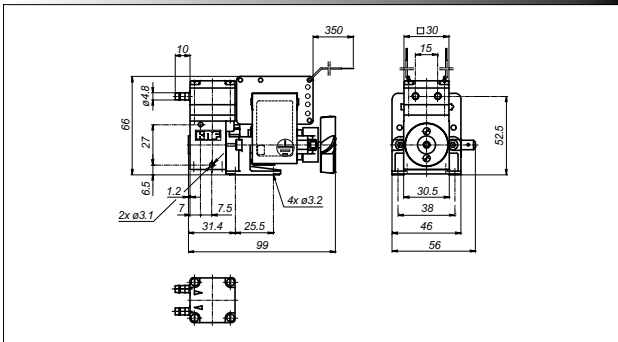

### NF 60-DC

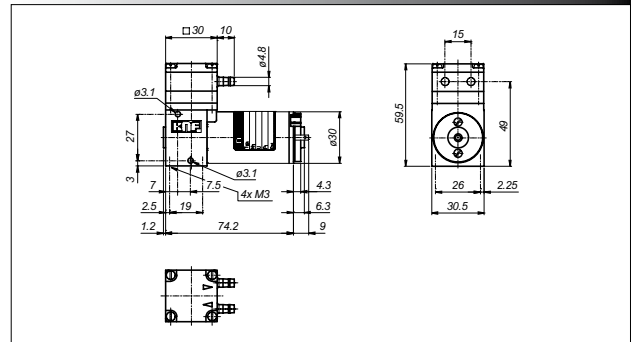

### NF 60-DCB

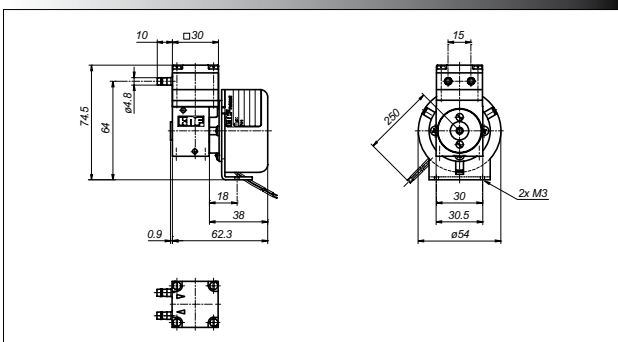

### NF 61-DC

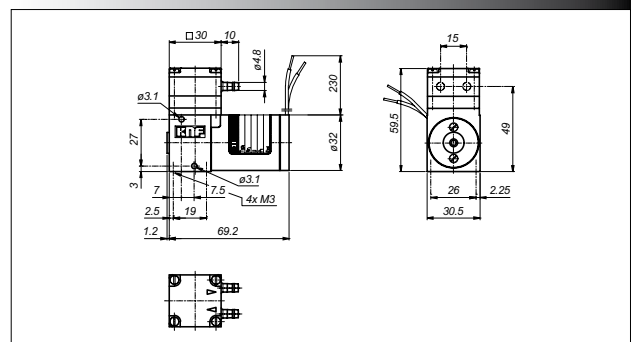

### NF 60-E

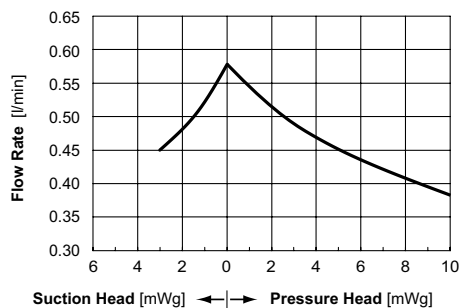

### NF 60-DC NF 60-DCB NF 61-DC

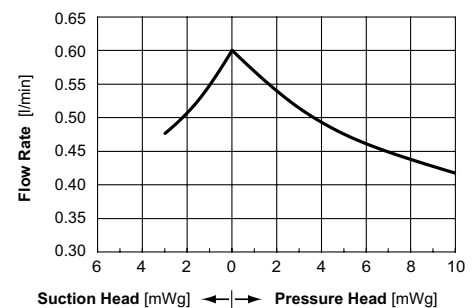



## Performance

Basic model	Flow rate at atmos. pressure (l/min)	Max. suction head (mWg)	Max. pressure head (mWg)
NFB 60 DCB	2 x 0.6	3	10

Motor selection	<b>DCB</b>
Voltage (V)	12 / 24
Power rating (W)	18 / 18
I max. load (A)	1.1 / 0.5
I max. (A)	1.5 / 0.75
EMC guideline	EN 55014-1 <sup>1)</sup> EN 61000-2-6
Motor protection factor	IP 30
Weight	370 g

<sup>1)</sup> In order to comply with the above standards attention must be paid to the specifications in the operating instructions.

## Accessories

### Diaphragm pressure control valve

The pressure control valve can be used for a more accurate control of flow against a fluctuating back pressure, metering into a vacuum and from a pressurised system. Used correct it can save pumps, plumbings and other fittings from damage. Example FDV 30 KPZ, for more information see data sheet FDV

### Pulsation damper

This very versatile pulsation damper reduces the vibration in hoses and pipes and it helps to remove pulsation which is preventing the system from functioning correctly. It also protects instrumentation connected after the pump. Suggestion FPD 06 KPZ-1, for more details see data sheet FPD

### Further accessories

- Hoses
- Hoses connections
- Shock mounts
- Suppression device for DCB motor (ID-Nr. 068 713)

## NFB 60 DCB

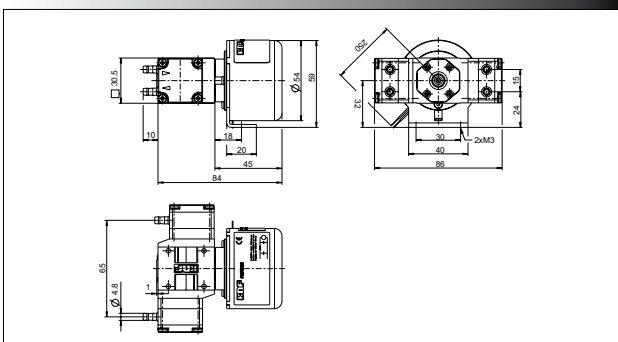

Flow rate per pump head

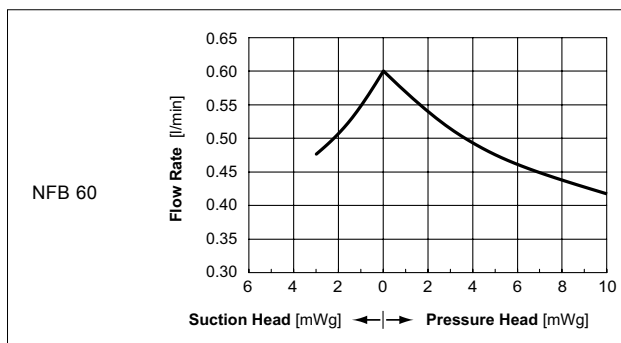

## Options



### NSF National Sanitary Foundation

NSF is market leader in the development and controlling of standards relevant for equipment used for handling foodstuffs. By using different toxicological tests our products will be certified according to the standard NSF/ANSI 169. This certification will confirm that all of the pumps with the code .51 are certified for the use with foods/consumables. In addition to this it also means that the pumps are constructed with wetted parts which come with a FDA\* declaration of conformity. A yearly audit from NSF will be carried out to ensure that these standards are being maintained. A list of the various products are available on request.

\* FDA = Food and Drug Administration

### Further options

- **Connections:** M5, UNF 1/4"-28, 4/6 mm hose connector
- **Head material:** Stainless steel, PPS, PA MXD 6 etc.
- Suitable for pressure over 1.0 bar
- High protection IP65 version for applications under bad conditions (moisture, dust), for NF 60/61-DC
- Motors with special voltages and frequencies
- The incorporation of customers special requirements, for example special electrical connections (Molex, AMP, etc.)

**We specialise in tailor made solutions. For all the possible options please feel free to contact us.**

KNF FLODOS AG, Wassermatte 2, 6210 Sursee, Switzerland - [www.knf-flodos.ch](http://www.knf-flodos.ch), [info@knf-flodos.ch](mailto:info@knf-flodos.ch)

INNOVATIVE  
TECHNOLOGY  
WORLDWIDE

